

**COBALT FINISHING END MILLS**

Multi flute Finishing end mills  
 Super Cobalt - Regular Length  
 For titanium and high tensile materials  
 Center Cutting

**FRAISES DE FINITION EN COBALT**

Fraises de Finition multi dents  
 Super Cobalt – Série Normale  
 Pour titan et matériaux exotiques  
 Coupe au Centre

**FRESAS DE ACABADO IN COBALTO**

Fresas para Acabado multi labios  
 Super Cobalto – Seria Normal  
 Para titanio y materiales esoticos  
 Corte al Centro

**LIST 865**

**M-42**

35°

 WELDON  
 FLAT

D	d	/	L	Z	Tool No. Uncoated	Tool No. TiCN	Tool No. TiAlN
1/8	3/8	3/8	2-5/16	4	865-4	TC865-4	TA865-4
3/16	3/8	1/2	2-3/8	4	865-6	TC865-6	TA865-6
1/4	3/8	5/8	2-7/16	4	865-8	TC865-8	TA865-8
5/16	3/8	3/4	2-1/2	4	865-10	TC865-10	TA865-10
3/8	3/8	3/4	2-1/2	4	865-12	TC865-12	TA865-12
1/2	1/2	1-1/4	3-1/4	4	865-16	TC865-16	TA865-16
5/8	5/8	1-5/8	3-3/4	4	865-20	TC865-20	TA865-20
5/8	5/8	1-5/8	3-3/4	6	865-20-A	TC865-20-A	TA865-20-A
3/4	3/4	1-5/8	3-7/8	4	865-24	TC865-24	TA865-24
3/4	3/4	1-5/8	3-7/8	6	865-24-A	TC865-24-A	TA865-24-A
7/8	7/8	1-7/8	4-1/8	4	865-28	TC865-28	TA865-28
7/8	7/8	1-7/8	4-1/8	6	865-28-A	TC865-28-A	TA865-28-A
1	1	2	4-1/2	4	865-32	TC865-32	TA865-32
1	1	2	4-1/2	6	865-32-A	TC865-32-A	TA865-32-A
1-1/4	1-1/4	2	4-1/2	4	865-40	TC865-40	TA865-40
1-1/4	1-1/4	2	4-1/2	6	865-40-A	TC865-40-A	TA865-40-A
1-1/2	1-1/4	2	4-1/2	4	865-48	TC865-48	TA865-48
1-1/2	1-1/4	2	4-1/2	6	865-48-A	TC865-48-A	TA865-48-A
2	1-1/4	2	4-1/2	6	865-64-40	TC865-64-40	TA865-64-40

**COBALT FINISHING END MILLS**

Multi flute Finishing end mills  
 Super Cobalt – Medium Length  
 For titanium and high tensile materials  
 Center Cutting

**FRAISES DE FINITION EN COBALT**

Fraises de Finition multi dents  
 Super Cobalt – Série Moyenne  
 Pour titan et matériaux exotiques  
 Coupe au Centre

**FRESAS DE ACABADO IN COBALTO**

Fresas para Acabado multi labios  
 Super cobalto – Seria Medio  
 Para titanio y materiales esoticos  
 Corte al Centro

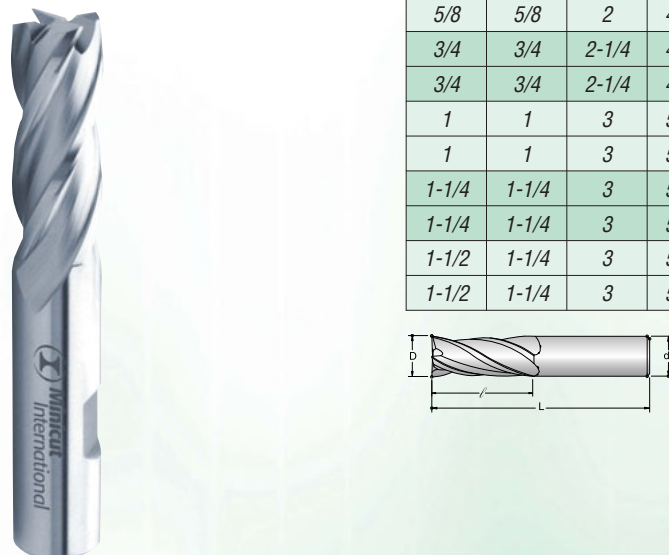
**LIST 867**

**M-42**

35°

 WELDON  
 FLAT

D	d	/	L	Z	Tool No. Uncoated	Tool No. TiCN	Tool No. TiAlN
5/8	5/8	2	4-1/8	4	867-20	TC867-20	TA867-20
3/4	3/4	2-1/4	4-1/2	4	867-24	TC867-24	TA867-24
3/4	3/4	2-1/4	4-1/2	6	867-24-A	TC867-24-A	TA867-24-A
1	1	3	5-1/2	4	867-32	TC867-32	TA867-32
1	1	3	5-1/2	6	867-32-A	TC867-32-A	TA867-32-A
1-1/4	1-1/4	3	5-1/2	4	867-40	TC867-40	TA867-40
1-1/4	1-1/4	3	5-1/2	6	867-40-A	TC867-40-A	TA867-40-A
1-1/2	1-1/4	3	5-1/2	4	867-48	TC867-48	TA867-48
1-1/2	1-1/4	3	5-1/2	6	867-48-A	TC867-48-A	TA867-48-A