

MEGAMILL – End Mill Type - 40/50 - CAT, BT, NMTB

Patented, Breveté, Patentato

The Only Helical Positive Indexable Cutter
L'unique Fraise Hélicoidale avec Coupe Positive
La Unica Fresa Hélicoidal con Corte Positivo

METRIC SERIES

CAT 40/50V – DIN-69871A

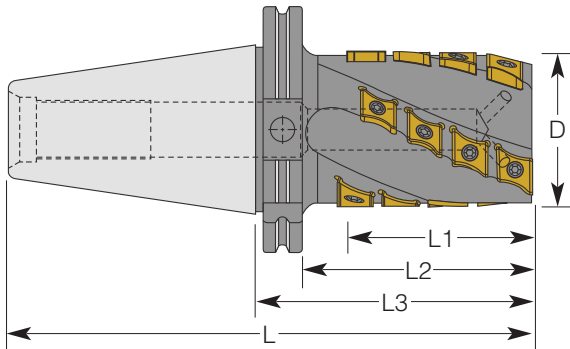

BT 40/50 – MAS 403 BT

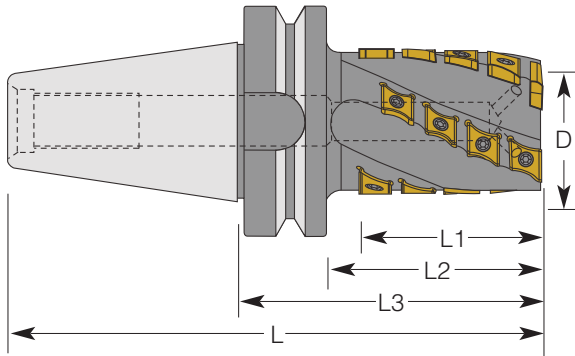

NMTB 40/50 – DIN-2080

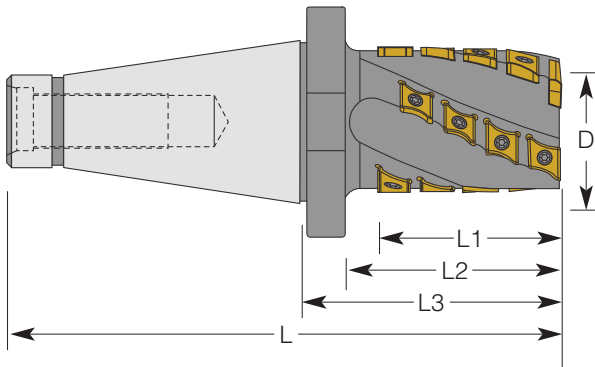

TOOL NO.	DIMENSIONS IN MM					NO. OF FLUTES Z	INSERTS NO.			
	D	L1	L2	L3	L		Side Insert	Qty	End Insert	Qty
MM-32474 CAT40V	32	47	67	86	154	4	CMSI-450	12	—	—
MM-32474 BT40	32	47	67	94	159	4	CMSI-450	12	—	—
MM-32474 ISO40	32	47	67	86	171	4	CMSI-450	12	—	—
MM-32624 CAT40V	32	62	82	101	169	4	CMSI-450	16	—	—
MM-32624 BT40	32	62	82	109	174	4	CMSI-450	16	—	—
MM-32624 ISO40	32	62	82	101	194	4	CMSI-450	16	—	—
MM-40474 CAT40V	40	47	67	86	154	4	CMSI-450	12	—	—
MM-40474 BT40	40	47	67	94	159	4	CMSI-450	12	—	—
MM-40474 ISO40	40	47	67	86	171	4	CMSI-450	12	—	—
MM-40624 CAT40V	40	62	82	101	169	4	CMSI-450	16	—	—
MM-40624 BT40	40	62	82	109	174	4	CMSI-450	16	—	—
MM-40624 ISO40	40	62	82	101	194	4	CMSI-450	16	—	—
MM-40624 CAT50V	40	62	82	101	202	4	CMSI-450	16	—	—
MM-40624 BT50	40	62	82	120	221	4	CMSI-450	16	—	—
MM-40624 ISO50	40	62	82	101	227	4	CMSI-450	16	—	—
MM-50814 CAT50V	50	81	100	119	221	4	CMSI-465	20	CMEI-687W CMEI-687C	2
MM-50814 BT50	50	81	100	138	240	4	CMSI-465	20		2
MM-50814 ISO50	50	81	100	119	246	4	CMSI-465	20		2
MM-501024 CAT50V	50	102	121	140	242	4	CMSI-465	26		2
MM-501024 BT50	50	102	121	159	261	4	CMSI-465	26		2
MM-501024 ISO50	50	102	121	140	267	4	CMSI-465	26		2
MM-63824 CAT50V	63	82	121	120	222	4	CMSI-620	16		2
MM-63824 BT50	63	82	121	139	241	4	CMSI-620	16		2
MM-63824 ISO50	63	82	121	120	247	4	CMSI-620	16		2
MM-631014 CAT50V	63	101	120	139	241	4	CMSI-620	20		2
MM-631014 BT50	63	101	120	158	260	4	CMSI-620	20	2	
MM-631014 ISO50	63	101	120	139	266	4	CMSI-620	20	2	