

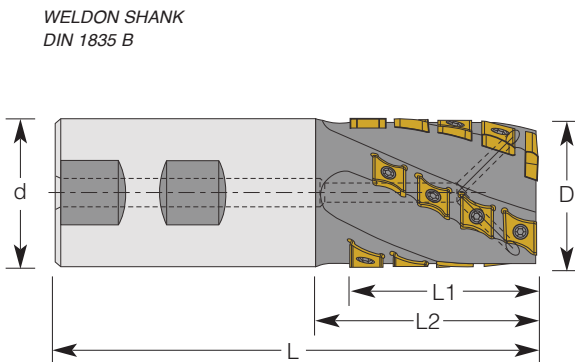

## MEGAMILL — End Mill Type - Straight Shank

Patented, Breveté, Patentato

The Only Helical Positive Indexable Cutter  
 L'unique Fraise Hélicoidale avec Coupe Positive  
 La Unica Fresa Hélicoidal con Corte Positivo

### METRIC SERIES



TOOL NO.	DIMENSIONS IN MM						NO. OF FLUTES	INSERTS NO.			
	D	d	L1	L2	L	Z		Side Insert 	Qty	End Insert 	Qty
MM-25293-W 25	25	25	29	32	95	3	CMSI-387	8	—	—	
MM-25443-W 25	25	25	44	50	115	3	CMSI-387	12	—	—	
MM-32474-W 32	32	32	47	60	120	4	CMSI-450	12	—	—	
MM-32624-W 32	32	32	62	79	140	4	CMSI-450	16	—	—	
MM-40474-W 32	40	32	47	54	120	4	CMSI-450	12	—	—	
MM-40624-W 32	40	32	62	73	140	4	CMSI-450	16	—	—	
MM-50514-W 32	50	32	50	60	124	4	CMSI-465	12	CMEI-687W	2	
MM-50814-W 50	50	50	81	107	190	4	CMSI-465	20		2	
MM-501014-W 50	50	50	101	127	210	4	CMSI-465	26	CMEI-687C	2	
MM-63724-W 50	63	50	72	82	178	4	CMSI-620	14		2	
MM-631014-W 50	63	50	101	111	206	4	CMSI-620	20	2		

### METRIC SERIES

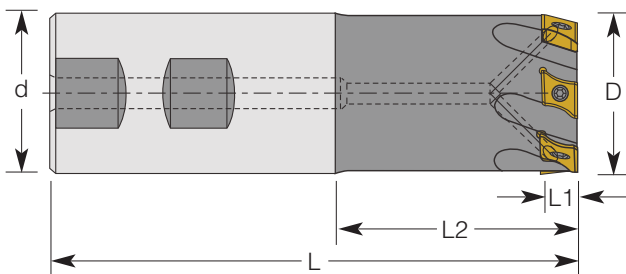

TOOL NO.	DIMENSIONS IN MM						NO. OF FLUTES	INSERTS NO. 
	D	d	L1	L2	L	Z		
MME-209002-W 20	20	20	9	34	95	2	CMSI-387	
MME-259003-W 25	25	25	9	38	95	3	CMSI-387	
MMEE-259003-W 25	25	25	9	89	150	3	CMSI-387	
MME-329004-W 25	32	25	11	34	100	4	CMSI-450	
MME-329003-W 32	32	32	11	38	108	3	CMSI-450	
MME-409005-W 25	40	25	11	34	102	5	CMSI-450	
MME-409004-W 32	40	32	11	38	114	4	CMSI-450	
MMEE-329004-W 32	32	32	11	102	165	4	CMSI-450	
MMEE-409005-W 40	40	40	11	127	197	5	CMSI-450	
MME-509004-W 25	50	25	12	57	114	5	CMSI-465	
MME-509004-W 32	50	32	12	57	114	5	CMSI-465	
MME-639004-W 32	63	32	16	57	114	5	CMSI-620	
MME-639004-W 50	63	50	16	57	152	5	CMSI-620	